

## 100% Battery Driven

Patented (pending) drive system with the most modern screw and nut system. Machine room less. State of the art 48V battery driven IPM-SynRM motor with next generation motor control technology.



**EcoDrive**  
48V battery bank dynamically charged.

- When traveling down
- By battery charger
- By solar panels (optional)



**A-rated energy consumption**  
At full operation, energy consumption is similar to an A-rated dishwasher (according to VDI 4707). The market's lowest maintenance cost thanks to the EcoDrive.



**Easy installation**  
All inclusive lift + shaft. Possible to install directly on the floor. 230V single phase installation.



**Anti-trap system**  
Full operation if external power failure. No need to be anxious.



**SWIFT Remote**  
Always connected and remotely monitored to minimize maintenance and service costs and to optimize functionality.



**Sustainability**  
More than 90% of the components in the lift are recyclable.



**Technical compliance**  
Complies with Europe's strictest safety requirements European Machinery Directive 2006/42/EC.



# Exclusive to Aussie Lifts

## SWIFT Lite

SWIFT home lifts represents the future of stylish living, allowing you to move smoothly and swiftly between different floors in your home. Enjoy everyday luxury and the highest level of safety for peace of mind.

SWIFT is specifically designed to be integrated with your home without any of the complicated building works required with traditional elevators. It is safe, smart and silent.

SWIFT Lite is designed to meet the requirements of a limited budget without compromising on style and comfort.

Contact us on **1800 287 543** or at **[info@aussielifts.com.au](mailto:info@aussielifts.com.au)**

Please visit **[aussielifts.com.au](http://aussielifts.com.au)** for more information.

**aussielifts**

# SWIFT Lite

The home lift consists of a L-shaped platform with a floor that moves you up and down. The lift is controlled by classic lift buttons in stainless steel.

## Light

Carrier: White LED

## Doors

Double glass doors with automatic openers/closers. Built-in obstacle detection, stay open function and possibility to set door speed.

## Carpets:

SWIFT Lite comes with a Vinyl Black carpet as standard. The carpet is a woven vinyl and easy to clean. As an option you can choose a flooring made by the Danish design company Ege Carpets. The yarn is a recycled micro fibre.

Vinyl Black | Standard

Una Micro Grey | Option



Shaft and lift colour

Glass or metal panels. Three colours to choose from.

Standard:

Traffic White  
RAL 9016

Options:

Jet Black  
RAL 9005

Gold  
New colour  
for 2023

Plattform wall  
Grey white resin board.



Handrail  
Choose between a black or white handrail.

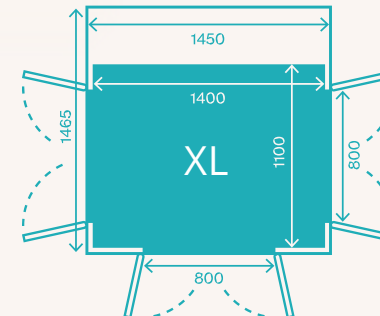
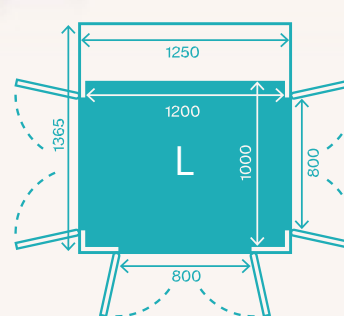
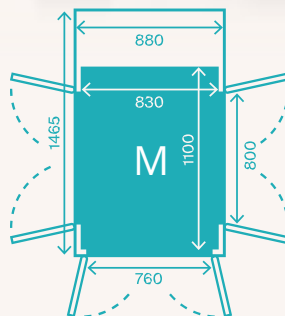
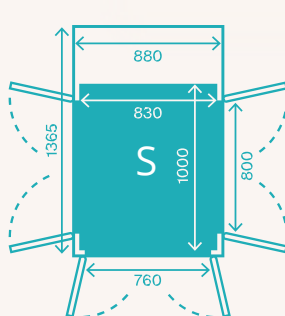

## Lift sizes:

\*Recommended size (for hole through the floor)

Size:	830x1000 mm	830x1100 mm	1200x1000 mm	1400x1100 mm
Rated load:	250 kg / 3 persons	250 kg / 3 persons	400 kg / 5 persons	400 kg / 5 persons
Hole through floor*:	940x1425 mm	940x1525 mm	1310x1425 mm	1510x1525 mm

## Technical specifications

Floors: 2-6 floors  
Travel: 250 to 15.000 mm  
Speed: 0.15 m/s (0.3 m/s as an option)  
Power: 230 V 1-phase 6 A (8 A fuse)  
Drive system: Patent pending screw and nut  
Installation: Recessed installation 50 mm (in line with the floor) or on top of the floor with a door sill.