

100% Battery Driven

SWIFT developed screw and nut drive, for a sweet sound of silence. Machine room less. State of the art 48V battery driven IPM-SynRM motor with next generation motor control technology.



EcoDrive
48V battery bank dynamically charged.

- When traveling down
- By battery charger
- By solar panels (optional)



A-rated energy consumption
At full operation, energy consumption is similar to an A-rated dishwasher (according to VDI 4707). The market's lowest maintenance cost thanks to the EcoDrive.



Easy installation
All inclusive lift + shaft. Possible to install directly on the floor. 230V single phase installation.



Touch display
Intuitive design. Name your floors. Set user profiles based on family member preferences for lift and door speed.



Customisable
Carefully selected ArtWalls, colours, light features and flooring options to make it fit any personal preferences.

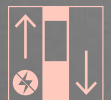

Anti-trap system
Full operation if external power failure. No need to be anxious.



SWIFT Remote
Always connected and remotely monitored to minimize maintenance and service costs and to optimize functionality.



Sustainability
More than 90% of the components in the lift are recyclable.



Technical compliance
Complies with Europe's strictest safety requirements European Machinery Directive 2006/42/EC.

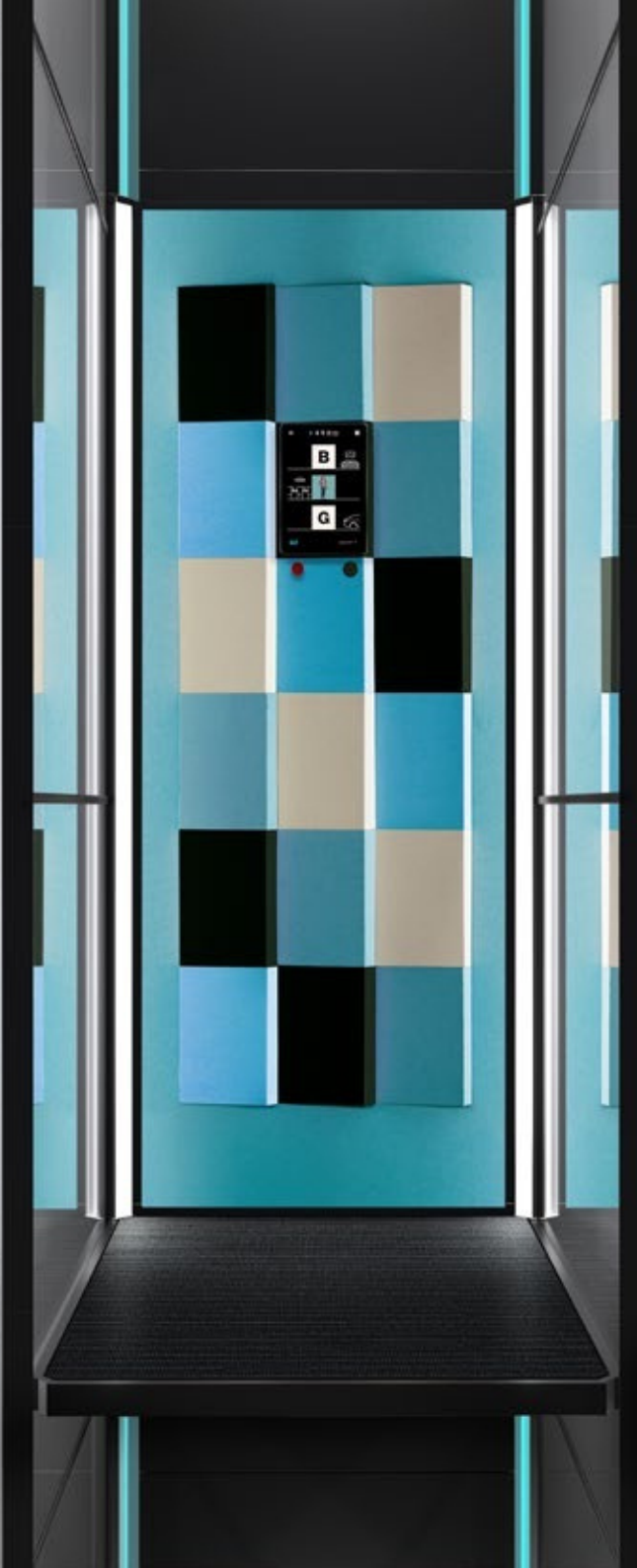

Exclusive to Aussie Lifts

SWIFT Pro

SWIFT home lifts represents the future of stylish living, allowing you to move smoothly and swiftly between different floors in your home. Enjoy everyday luxury and the highest level of safety for peace of mind.

SWIFT is specifically designed to be integrated with your home without any of the complicated building works required with traditional elevators. It is safe, smart and silent.

SWIFT Pro is our most advanced home lift with premium design features, a dynamic 10-inch touch display and several options for personalised settings.

Contact us on **1800 287 543** or at **info@aussielifts.com.au**

Please visit **aussielifts.com.au** for more information.

aussielifts

SWIFT Pro

The home lift consists of a shaft and a L-shaped platform with a floor that moves you up and down. The lift is controlled by a 10" Touch display full of smart features.

Light

Carrier: White LED
Shaft and ceiling: White or coloured LED.

Doors

Double glass doors with automatic openers/closers. Built-in obstacle detection, stay open function and possibility to set door speed.

Carpets:

Danish EGE Carpets in ECONYLO



Touch display functions
Different modes to meet different needs in everyday life. Floor lock to limit access to certain floors. Child lock to limit lift use. Customizable lift settings, travel view, light settings, etc.



Shaft and lift colour
Glass or metal panels. Five colours to choose from.

Standard:

Traffic White
RAL 9016

Options:

Grey White
RAL 9002

Anthracite Grey
RAL 7016

Jet Black
RAL 9005

Gold
New colour
for 2023

Handrail
Choose between a black or white handrail.

ArtWall

Several design themes to choose from; Electric Opal, Stockholm Grid, Orientalic White, INK Blue, Perching Bird and Bamboo Dreams. New designs added regularly.

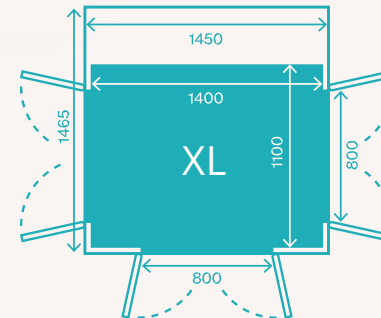
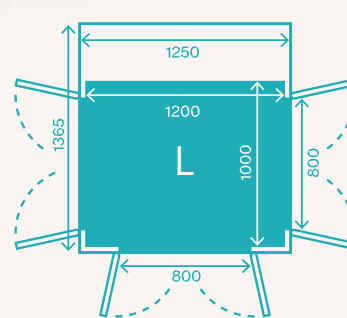
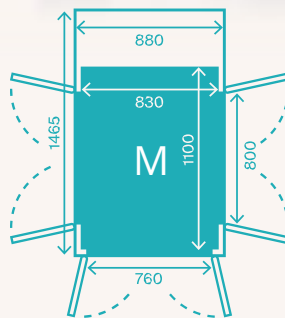
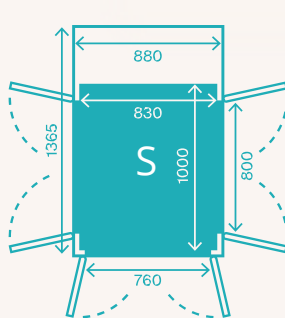
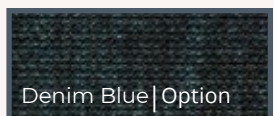
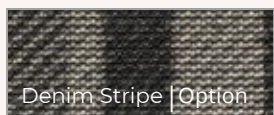
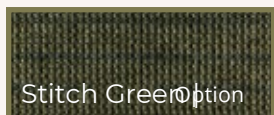
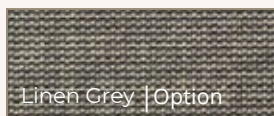
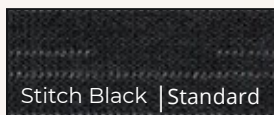
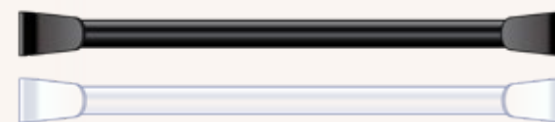
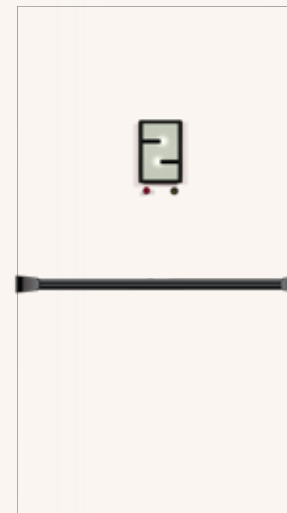

Lift sizes:

*Recommended size (for hole through the floor)

	Size: 830x1000 mm	830x1100 mm	1200x1000 mm	1400x1100 mm
Rated load:	250 kg / 3 persons	250 kg / 3 persons	400 kg / 5 persons	400 kg / 5 persons
Hole through floor*:	940x1425 mm	940x1525 mm	1310x1425 mm	1510x1525 mm

Technical specifications

Floors: 2-6 floors
Travel: 250 to 15.000 mm
Speed: Max 0.3 m/s (possible to adjust by user)
Power: 230 V 1-phase 6 A (8 A fuse)
Drive system: Patent pending screw and nut
Installation: Recessed installation 50 mm (in line with the floor) or on top of the floor with a door sill.